

4G/3G/LTE Antenna 900/1800/2100 MHz Cylinder Screw
Mounting
AN_GSM_023L

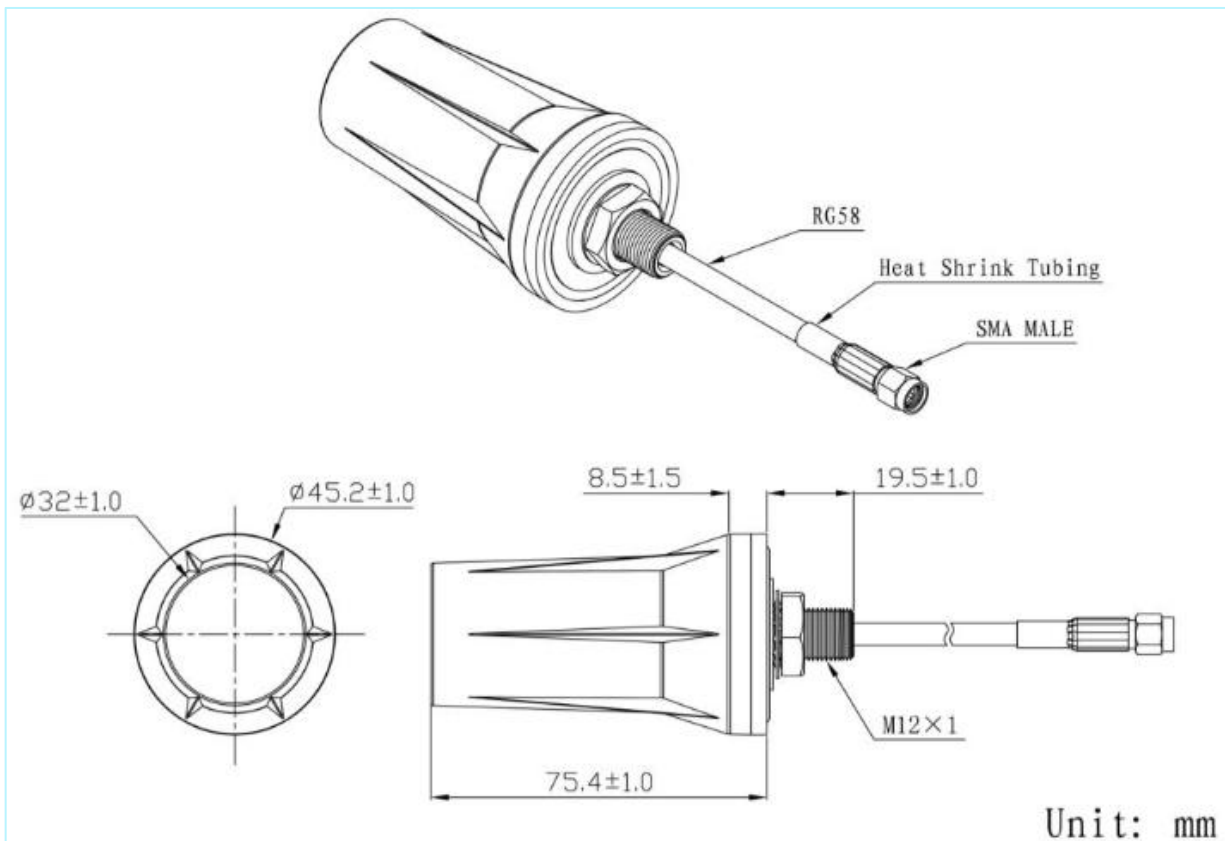

Mechanical dimension





4G/3G/LTE Antenna 900/1800/2100 MHz Cylinder Screw Mounting

Specifications

Item	Specifications	
Antenna	Frequency Range	698~960/1710~2690MHz
	Polarization	Linear
	Gain	2dBi (Zenith)
	V.S.W.R	≤3.0
	Impedance	50Ω
Mechanical	Cable	RG58 or others
	Connector	SMA or others
	Radome Material	ABS
	Mounting Method	Screw
Environmental	Operating Temperature	-40°C~+85°C
	Relative Humidity	Up to 95%
	Vibration	10 to 55Hz with 1.5mm amplitude 2hours
	Environmentally Friendly	ROHS Compliant

4G/3G/LTE Antenna 900/1800/2100 MHz Cylinder Screw Mounting

Radiation Patterns

